

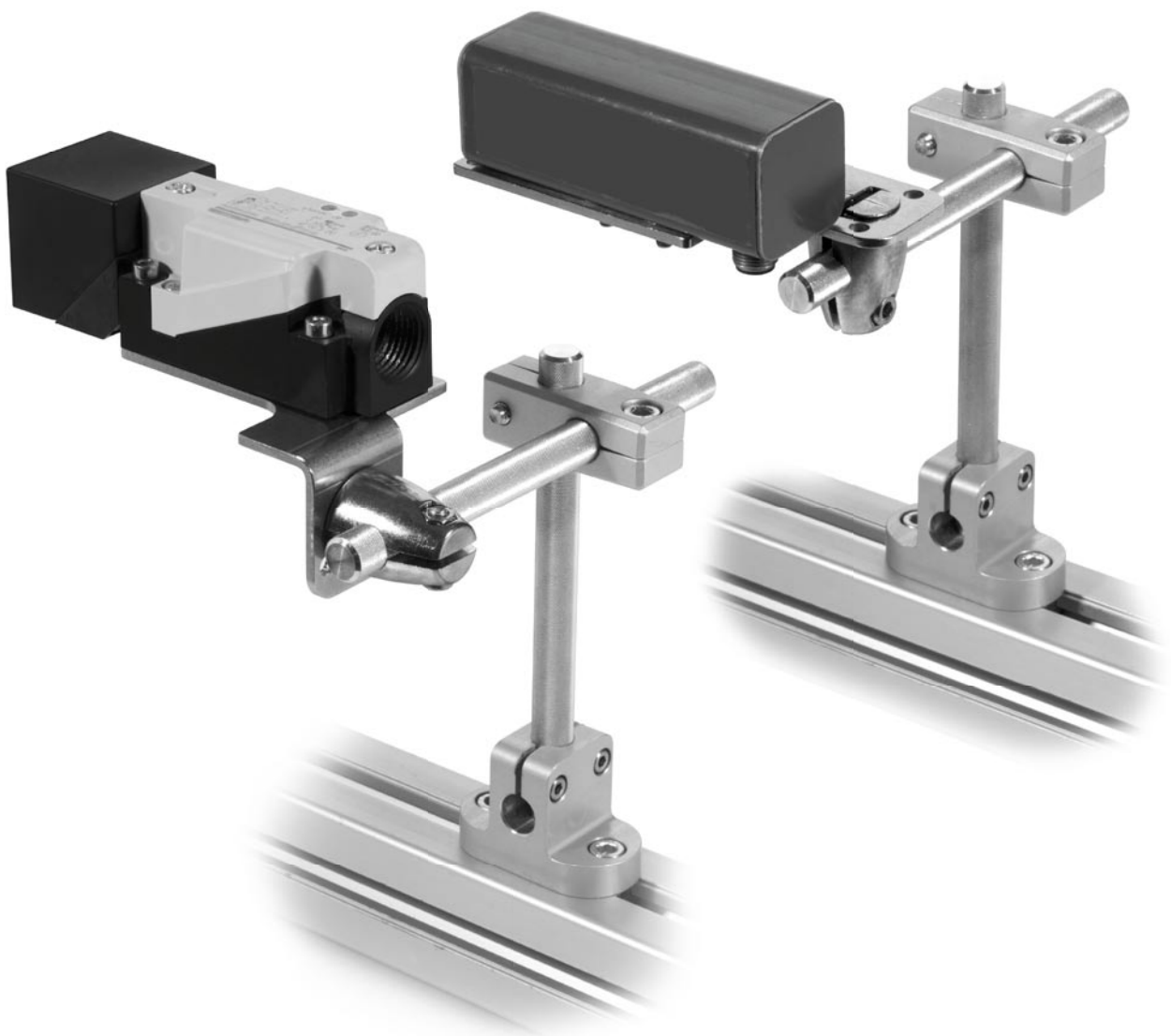







Mounting System HMS

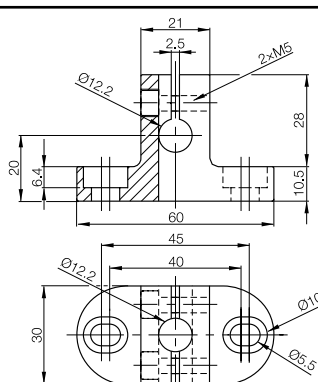
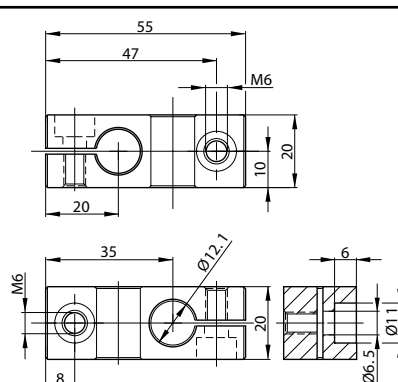
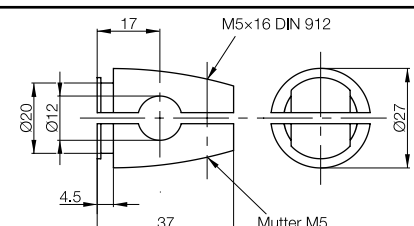

**To the optimized positioning of sensors
Simple and stable fixing in the construction process**

	Base holder	Cross-connectors	Clamping cylinder
	for mounting on base plates or rails for 1 rod Ø 12 mm (vertical or horizontal)	connecting element for 2 rods Ø12 mm	connecting element for 1 rod Ø12 mmr and sensor holder
			
Material	Al anodized	Al anodized	GD-Zn
Type	HMS GH1	HMS KV1	HMS KZ1
Art.-Nr.	9872A	9874A	9875A
			
	Sensor holder	Sensor holder	Mounting rod
	straight for IKU 0 and IKQ 0	right-angle for IKU 0 and IKQ 0	rod Ø 12 mm x 150 mm
			
Material	V4A	V4A	Al anodized
Type	HMS HUG	HMS HUW	HMS S15
Art.-Nr.	9871A	9871B	9873A
	